



SHOP PRESS ASSEMBLY INSTRUCTIONS



CP500 - 50 TON MANUAL SHOP PRESS WITH WINCH

PRESS SPECIFICATIONS

Arcan Model No.	A	B	C	D	E	F	G	H	I
CP500	74"	35"	29.75"	13"	6.75"	1.25"	Y	Y	Y(2)

- A - Total Height
- B - Inside Width
- C - Press Feet Length
- D - Bed Width
- E - Stroke (ram travel distance from fully retracted position to fully extended position)
- F - Pin Diameter
- G - PB Winch
- H - Sliding Head
- I - Press Plates Included

P.O. Box 58

Travelers Rest, SC 29690

Phone: (800) 879-7316

Fax: (864) 834-0073

SAFETY INFORMATION

⚠ WARNING

This symbol alerts you to the possibility of serious injury or death if instructions are not followed.

⚠ CAUTION

This symbol alerts you to the possibility of damage to or destruction of equipment if instructions are not followed.

⚠ WARNING

Failure to heed these warnings may result in loss of load, damage to the press and/or failure resulting in property damage, personal or fatal

injury. This operating manual contains important details concerning the safe operation of this tool. The user must read and understand these details before any use of the tool. This manual must be retained for future reference.

- Read, study, and understand all instruction manuals packed with this press before operating.
- Always wear safety goggles.
- Parts being pressed may splinter, shatter, or be ejected from the press at a dangerous rate of speed. Because of the variety of press applications, it is your responsibility to always use adequate guards and wear eye protection and heavy protective clothing when operating the press.
- Visual inspection should be made before each use of the press, checking for signs of cracked welds, bent bed pins, loose or missing bolts, leaks, or any other structural damage.
- Do not go near leaks. High pressure oil can puncture skin and cause serious injury, gangrene, or death. If injured, seek emergency medical help. Immediate surgery is required to remove oil.
- Keep hands and fingers out of the press and away from parts that may shift and pinch. Do not stand in front of work area when load is applied.
- Always use an accurate pressure gauge to measure pressing force.
- Do not exceed the rated capacity of this press.
- Never tamper with hydraulic system pressure settings.
- Do not substitute bolts, pins or any part of the components. Use only genuine factory replacement parts.
- Always center load on ram plunger. Offset loads can damage ram and may cause load to eject at a dangerous rate of speed.
- Remove all loads from press bed before attempting to adjust bed height. Beware of possibility of falling bed.
- Press only on loads supported by press bed and included press plates. Do not support loads on floor or press frame.
- When using any accessories such as arbor plates, be certain they are centered on press bed and are in full contact with press bed.
- Before applying load, be certain all press bed supporting pins are fully engaged.
- Always use a bearing shield when pressing bearings. Use caution when positioning work to be pressed to ensure that the item that is to be pressed cannot be dislodged or broken during press work. This may result in the item being ejected from the press at a dangerous rate of speed.
- Release hydraulic pressure before loosening any fittings.
- Maintain proper hydraulic fluid levels.
- Do not make any alterations to the press.

OWNER/USER RESPONSIBILITY

The owner and/or user must have an understanding of the manufacturer's operating instructions and warnings before using this press. Personnel involved in the use and operation of equipment must be careful, competent, trained, and qualified in the safe operation of the equipment and its proper use when servicing motor vehicles and their components. Warning information should be emphasized and understood.

If the operator is not fluent in English, the manufacturer's instructions and warnings must be read to and discussed with the operator in the operator's native language by the purchaser/owner, making sure that the operator comprehends its contents.

Owner and/or user must study and maintain for future reference the manufacturer's instructions. Owner and/or user is responsible for keeping all warning labels and instruction manuals legible and intact. Replacement labels and literature are available from the manufacturers.

INSPECTION

Visual inspection of the shop press should be made before each use of the press, checking for damaged, loose or missing parts. Each press must be inspected by a manufacturer's repair facility immediately if subjected to an abnormal load or shock. Any press which appears to be damaged in any way, is found to be badly worn, or operates abnormally must be removed from service until necessary repairs are made by a manufacturer's authorized repair facility. It is recommended that an annual inspection of the press be made by a manufacturer's authorized repair facility and that any defective parts, decals or warning labels be replaced with manufacturer's specified parts. A list of authorized repair facilities is available from the manufacturer.

SAFETY INSTRUCTIONS

- CHECK YOUR LOCAL, STATE AND FEDERAL REGULATIONS REGARDING THE SAFE USE OF THIS EQUIPMENT.
- Your safety is a top priority. Please handle equipment with care.
- Fully retract unit and remove all items from the press bed frame.
- Support the press bed and remove the pins.
- Raise or lower bed to desired height and reinstall press pins. Be certain pins are fully engaged in the parallel flanges of the upright columns.
- Position press on a flat, level, hard surface, preferably concrete. Make sure all nuts and bolts are tight.
- Clear the area of bystanders, especially small children, before using.
- Set the press bed to the required height. The press is most effective when the work piece is located 1 inch below the ram's retracted position. The compression stroke can include the entire 5 inch working range.
- The press is designed to exert a force on anything which is positioned beneath its ram. The work piece can be ejected from under the ram at a high rate of speed and can injure someone.
- Pressing Bearings: It is essential that you use the bearing shield when pressing bearings are on or off.

OPERATION

1. Press beds are adjustable up and down to fully take advantage of available ram travel and numerous work pieces.
2. Slowly open release valve on power unit. With the power unit in its stored position, remove all items from the press bed.
3. Be sure press bed is supported properly and remove press bed pins.
4. Raise or lower press bed to desired height, and reinstall press bed pins. Be certain pins are completely through both sides of frame, as these pins are the major support mechanism for the bed.

We want to know if you have any problems with our products.

If you are missing any parts or find any damage, call Arcan directly, and we will remedy the situation. Please do not call the store where you purchased this product.

Phone: (800) 879-7316

Email: arcanusa@bellsouth.net

PARTS LIST

ESTIMATED ASSEMBLY TIME: 45 MINUTES

Press Frame - 1

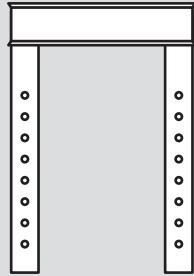

Press Bed - 1



Press Feet - 2



Z Bar - 1

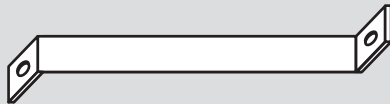

1/2"-13 x 1-1/2"
Hex Head Bolts - 8

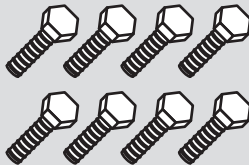

1/2" Nuts - 8

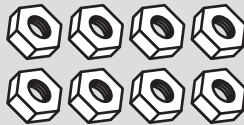

Washers - 8

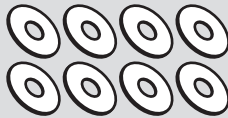

1-1/4" x 14"
Press Pins - 4

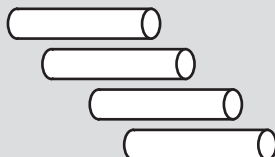

Two Stage
Pump and Ram - 1

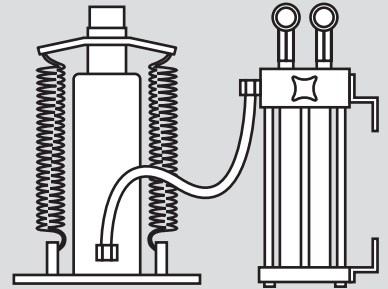

Ram Frame - 1



Pump Extension Handle - 1



ACCESSORIES

1" x 3" x 14"
Press Plates - 2

*Accessory only -
Not needed for assembly*

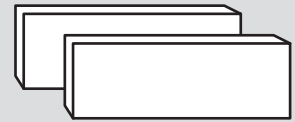

Pushing Adapter - 1

*Accessory only -
Not needed for assembly*



Bearing Shield - 1

*Accessory only -
Not needed for assembly*



TOOLS NEEDED

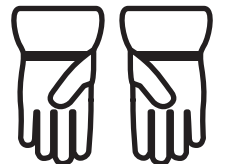
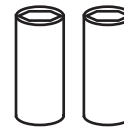

3/4" and 1/2" sockets and wrenches

Examine box contents, then proceed with the following instructions.

ASSEMBLY INSTRUCTIONS

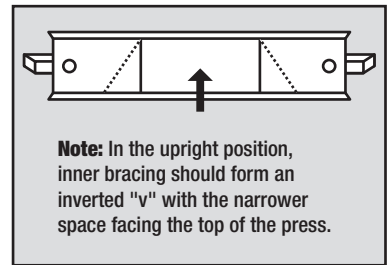
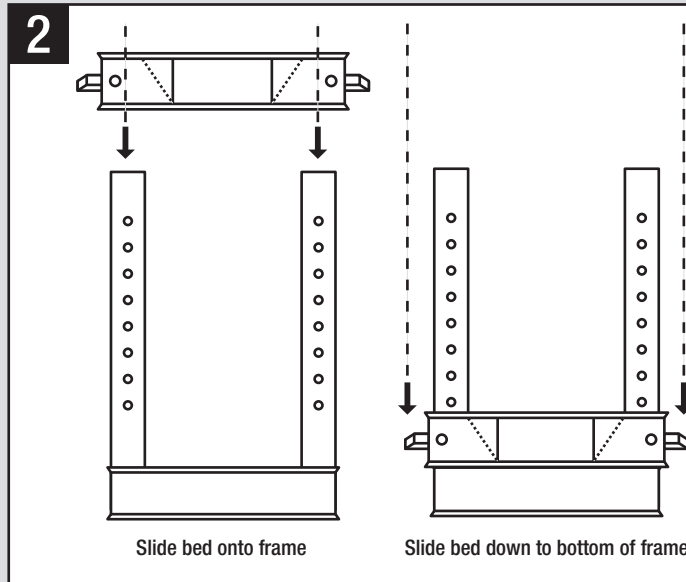
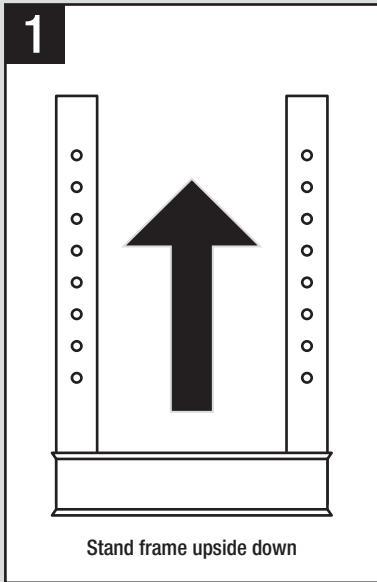

⚠ WARNING

Be aware of jagged edges on frame. Not all welds are smooth. Press bed can pinch or crush fingers. Wear safety gloves.

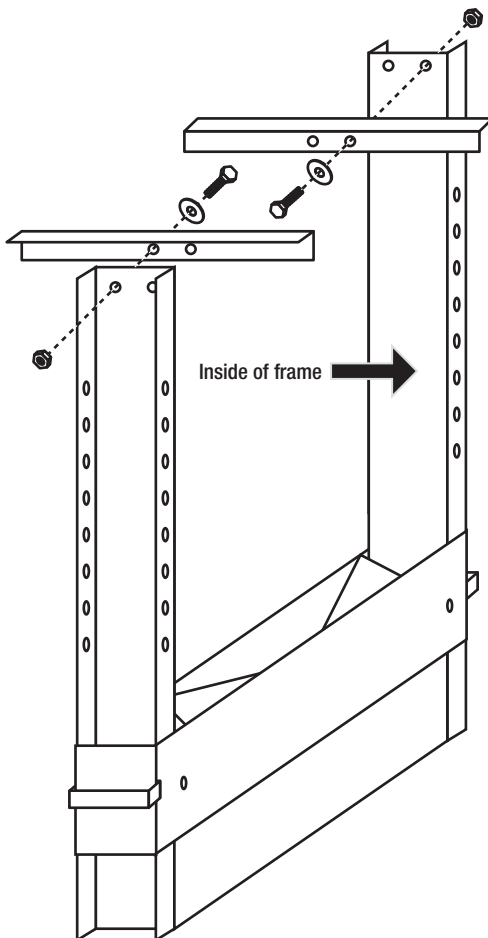
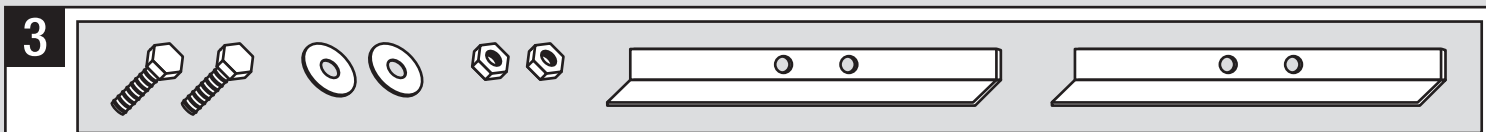

⚠ WARNING

Leg ends and press feet are sharp and potentially dangerous. Wear safety gloves and safety goggles.

Note: Position press feet on each side of the press. Attach one bolt, washer and nut on each side. Bolts should be attached *OFFSET* from one another.

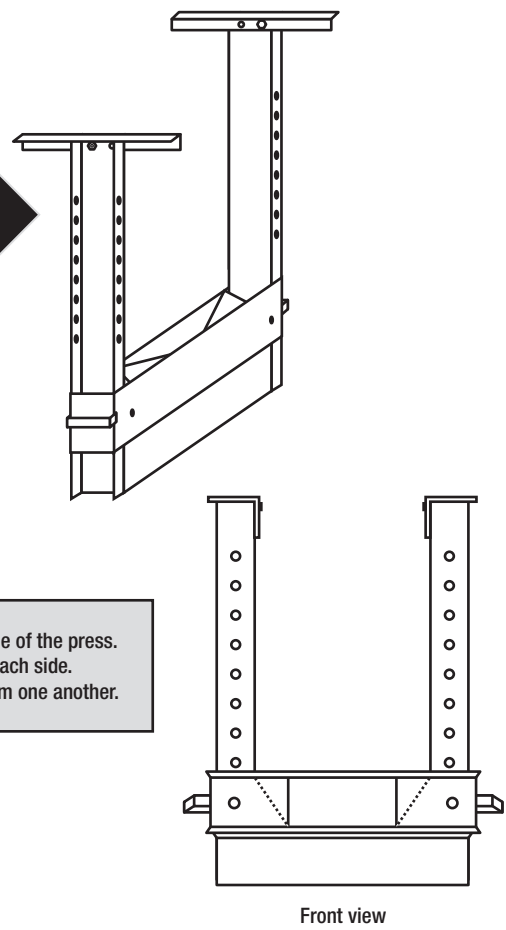

ASSEMBLY INSTRUCTIONS CONTINUED

4

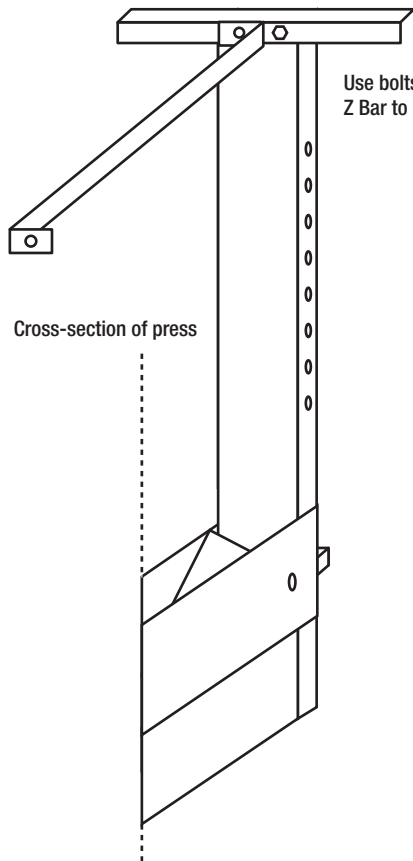
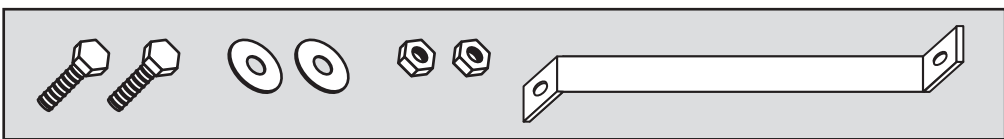

Use bolts, washers and nuts to attach Z Bar to both sides of the press.

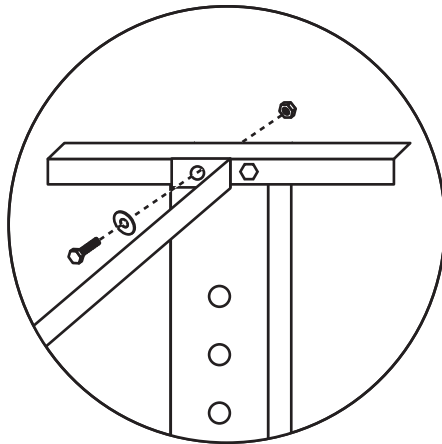

Note: Check all bolts for tightness. If press rocks, or is not level, loosen press feet slightly to compensate and retighten.

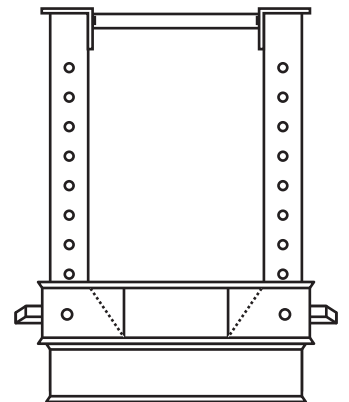
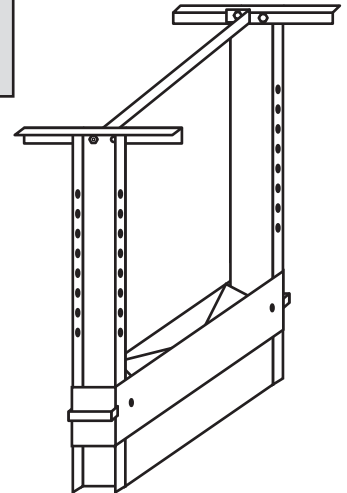

Front view

5

⚠ WARNING

Bed must be at the **BOTTOM** of the frame before proceeding to the next step.

Note: When sliding bed to frame bottom, **DO NOT** use bed handles.

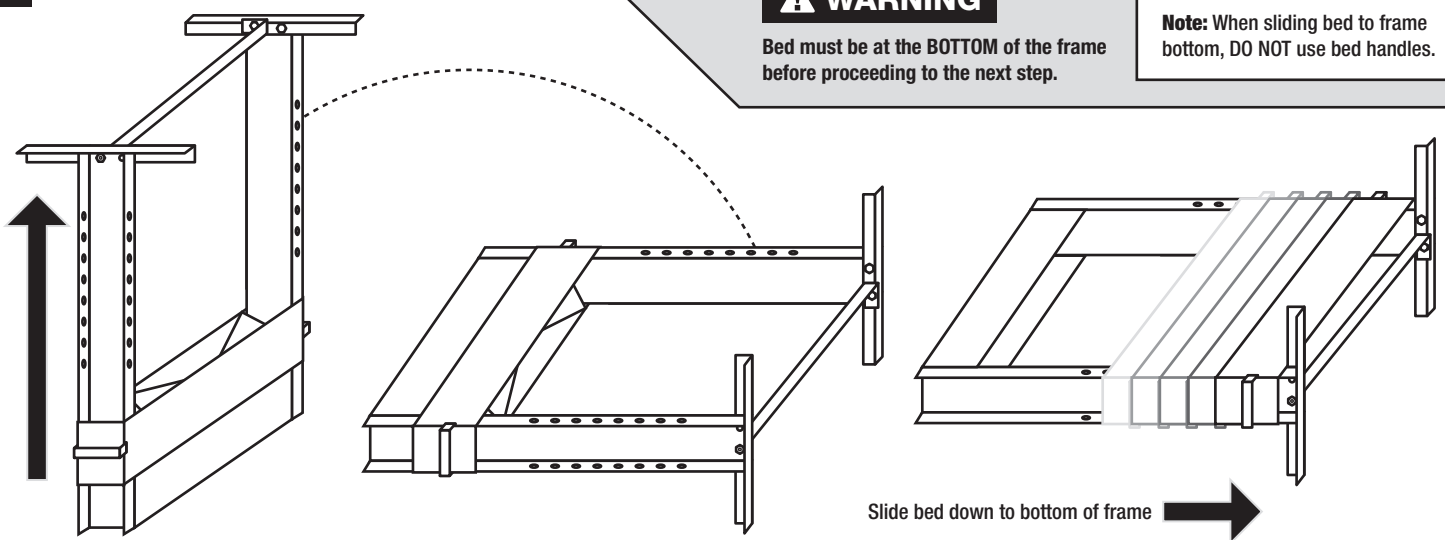

ASSEMBLY INSTRUCTIONS CONTINUED

6

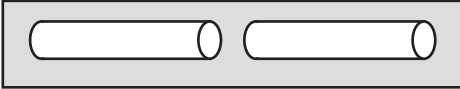

⚠ WARNING

Pins must be COMPLETELY through BOTH SIDES of frame.

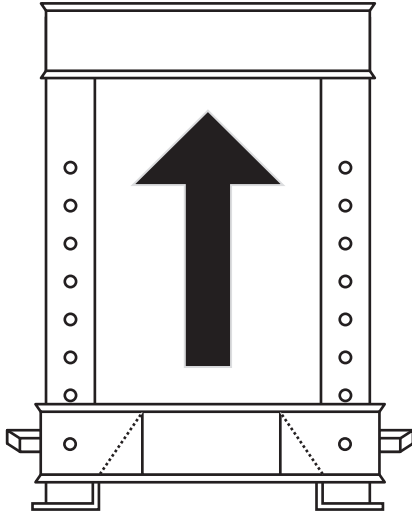

Stand unit upright

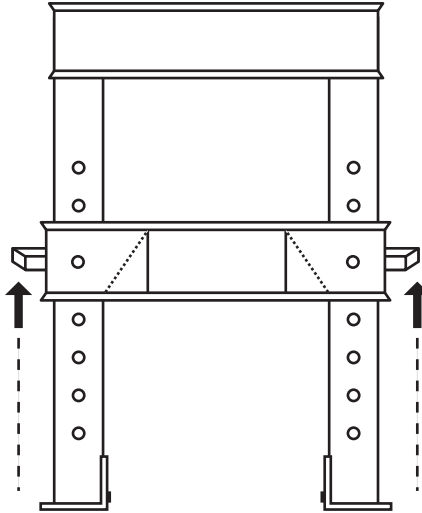

Slide bed above holes and *hold in place*

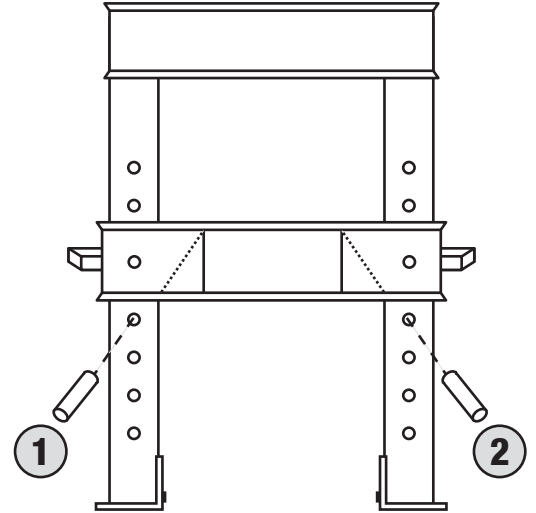

Secure pins underneath bed, one at a time

7

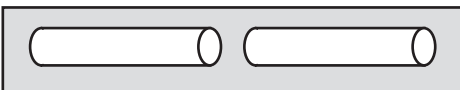

⚠ WARNING

ALL FOUR (4) pins must be COMPLETELY through BOTH SIDES of frame in order to operate press.

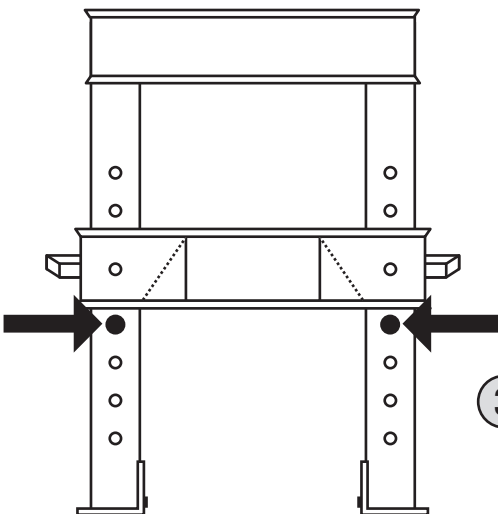

Let bed rest on inserted pins

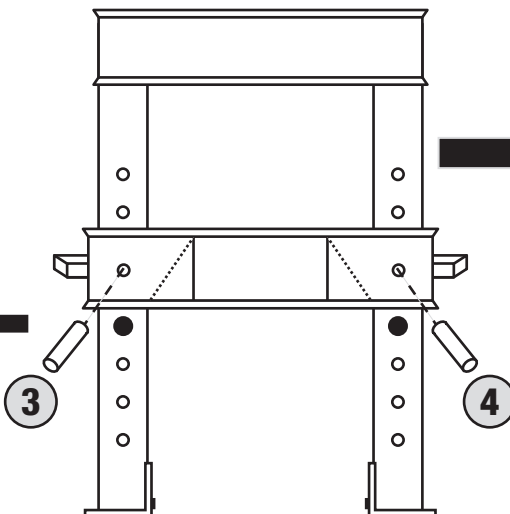

Place 3rd and 4th pin on each side

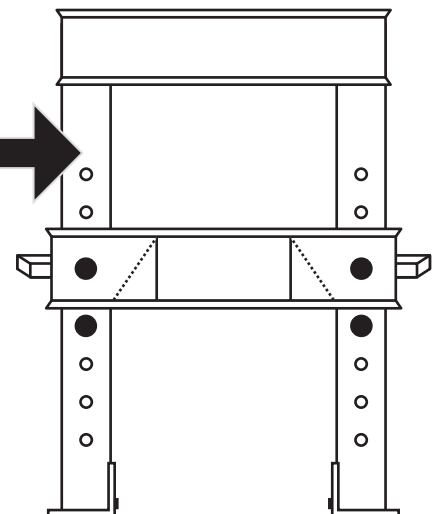

Secure pins completely through bed and frame.

RAM FRAME ASSEMBLY INSTRUCTIONS

8

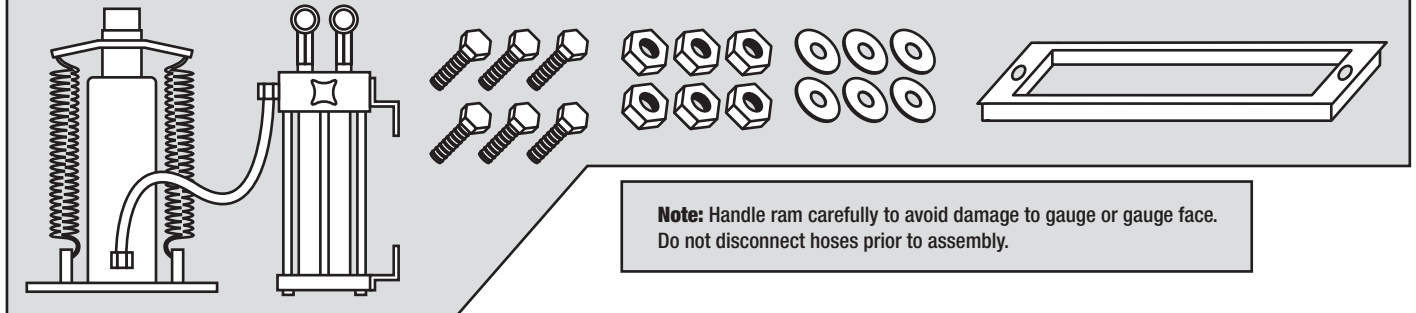

Note: Handle ram carefully to avoid damage to gauge or gauge face. Do not disconnect hoses prior to assembly.

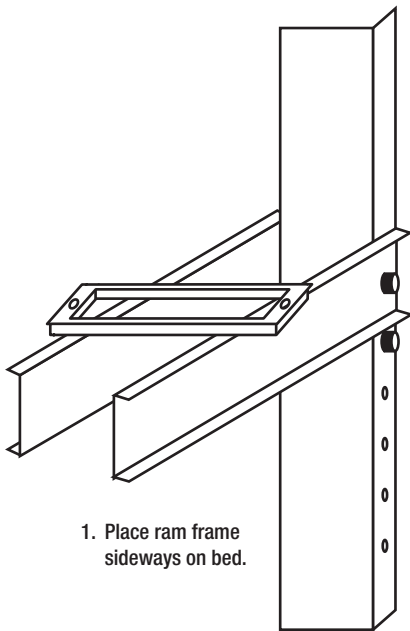

1. Place ram frame sideways on bed.

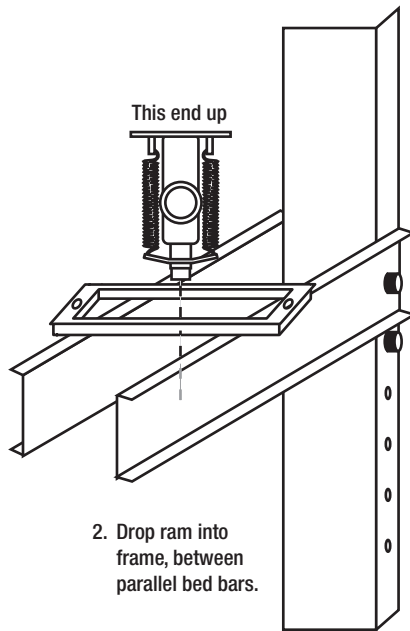

2. Drop ram into frame, between parallel bed bars.

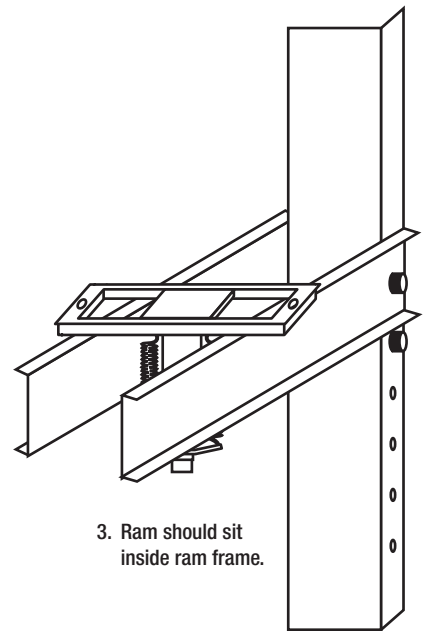

3. Ram should sit inside ram frame.

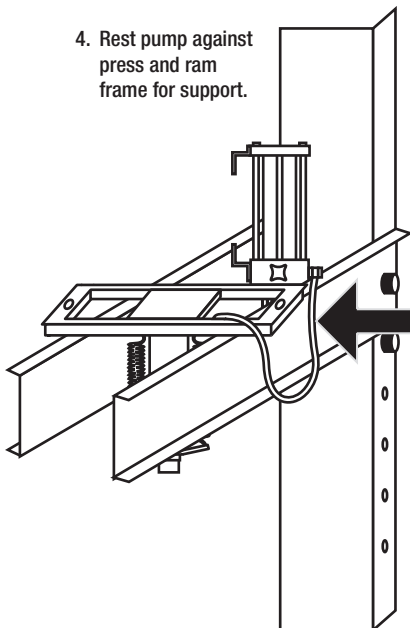

4. Rest pump against press and ram frame for support.

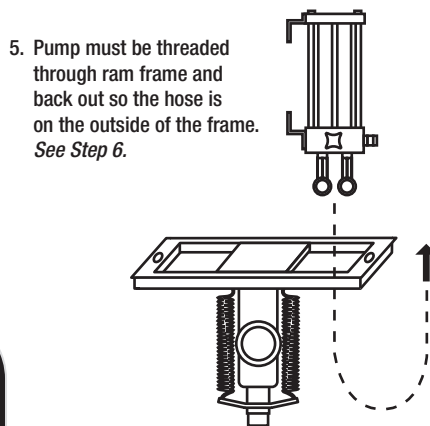

5. Pump must be threaded through ram frame and back out so the hose is on the outside of the frame. See Step 6.

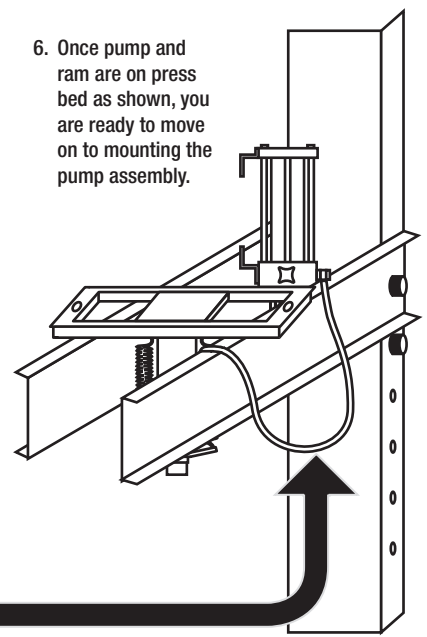

6. Once pump and ram are on press bed as shown, you are ready to move on to mounting the pump assembly.

WARNING
Hose must be on the OUTSIDE of ram frame, or it will NOT be mountable to the press.

PUMP AND RAM ASSEMBLY INSTRUCTIONS

9

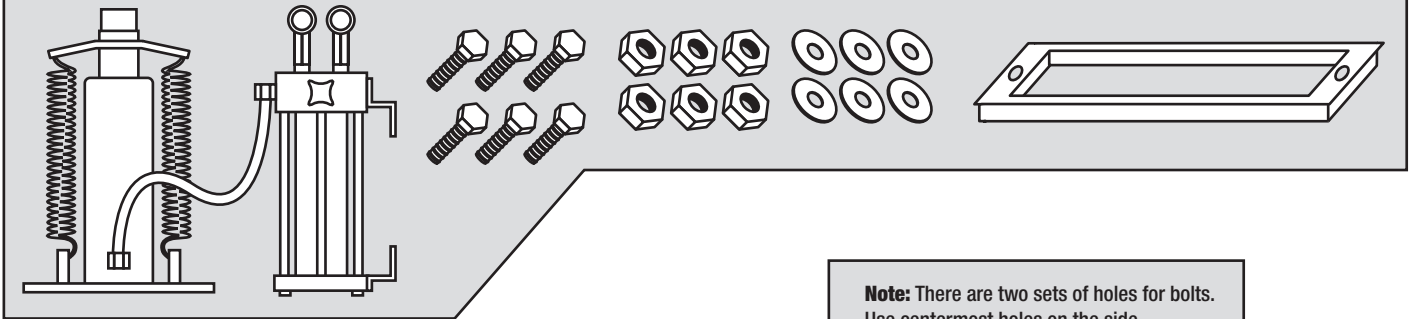

Note: There are two sets of holes for bolts. Use centermost holes on the side.

A

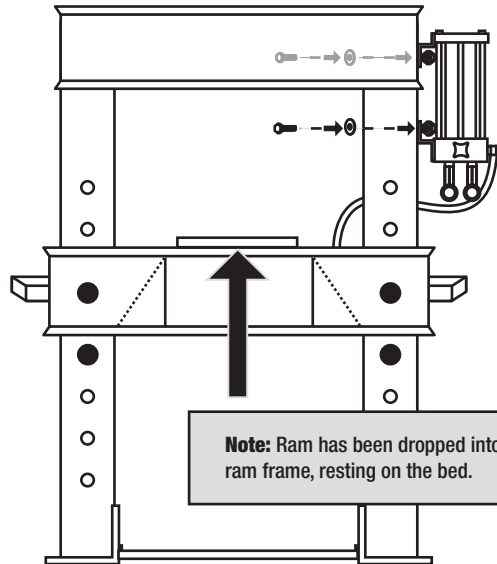
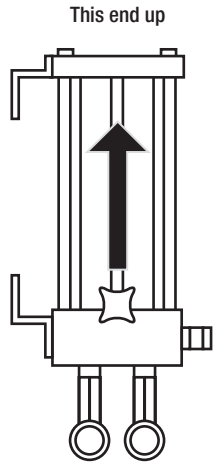

Note: Hose must run BEHIND frame. DO NOT disconnect hose from pump or ram.

Note: Ram has been dropped into ram frame, resting on the bed.

B

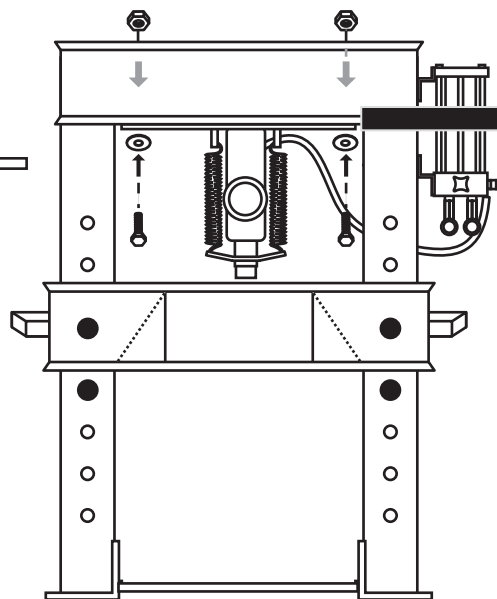
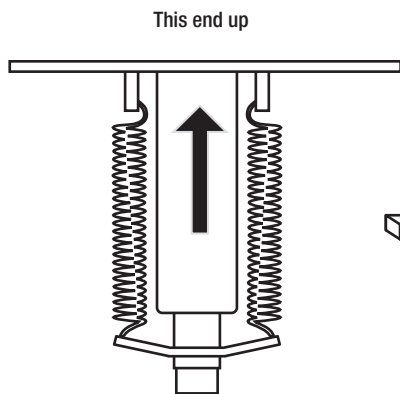

Attach bolts up through ram frame to matching holes in press. Hand tighten. Wrench tighten after both bolts have been installed. Ram is now able to slide left and right within ram frame.

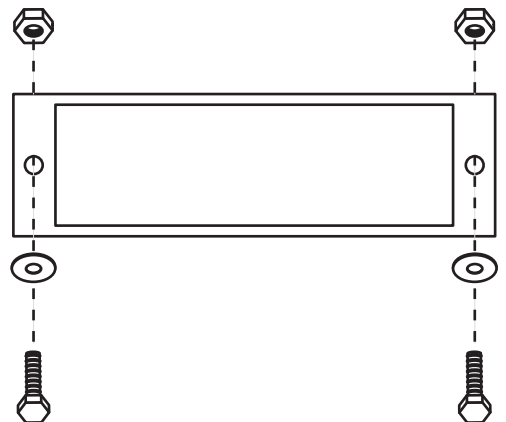

WARNING

DO NOT attempt to operate pump unless the BREATHER VALVE IS OPEN. Valve is closed prior to shipping to prevent the loss of hydraulic fluid.

PROCEDURE FOR BLEEDING AIR

10

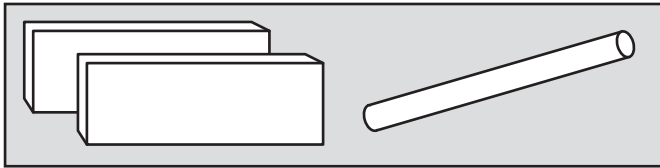

1. Turn valve handle on FRONT of pump CLOCKWISE until closed. DO NOT OVERTIGHTEN.

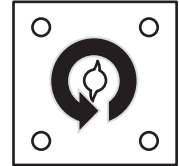

2. Turn petcock valve (breather) on TOP of pump COUNTERCLOCKWISE to open.

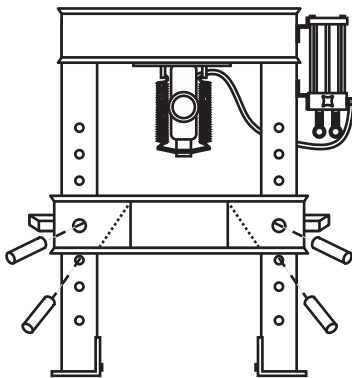

3. Move press bed into highest position and lock bed into place with both pins.

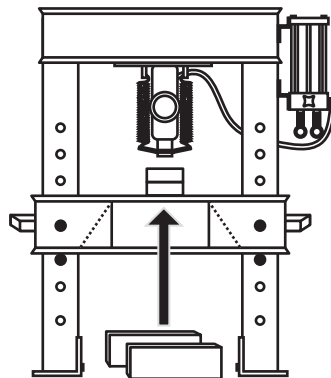

4. Place press plates DIRECTLY under ram, on press bed.

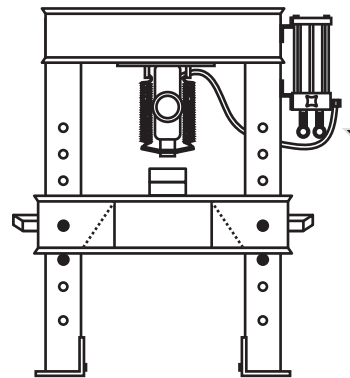

5. Put cradle in the DOWN position. Use an adapter on your air hose and allow air to flow through the opening in the petcock valve into the pump.

CAUTION

Bed must be in UP position, or you will over extend ram.

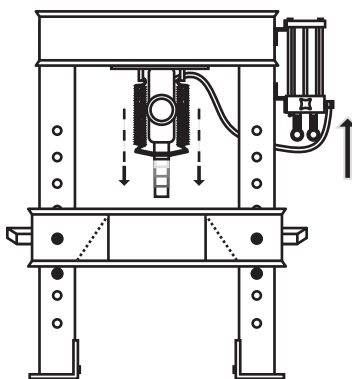

6. Air that has flowed into the pump causes the cradle to move up and the ram to move down. If this happens, proceed to step 7. If not, check all hoses and connections and repeat the procedure.

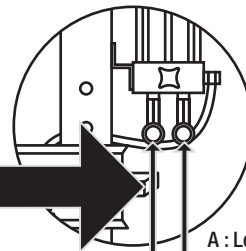

A : Low Pressure Cradle
B A B : High Pressure Cradle

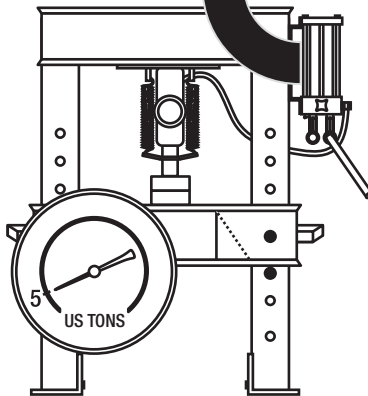

7. Insert pump handle into LOW PRESSURE CRADLE. Pump ram against press plates until gauge reads "5 Tons".

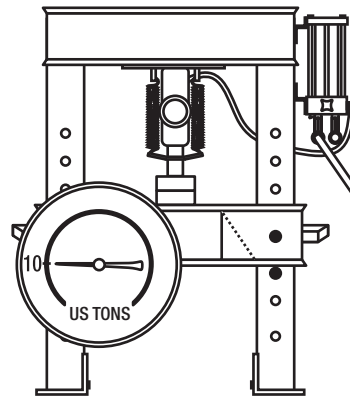

8. Insert pump handle into HIGH PRESSURE CRADLE. Pump ram against press plates until gauge reads "10 Tons".

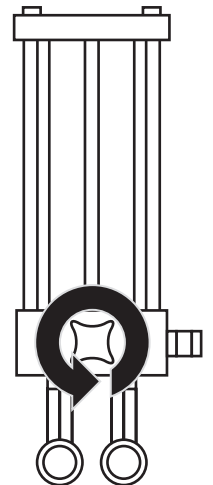

9. Turn valve handle on pump COUNTERCLOCKWISE a maximum of one (1) turn to open valve. Ram will retract as pressure is released.

WARNING

Do not allow the ram to extend more than 5.5".

PUMP INSTRUCTIONS

11

⚠ WARNING

This symbol alerts you to the possibility of serious injury or death if instructions are not followed.

Failure to heed these warnings may result in loss of load, damage to the press and/or failure resulting in property damage, personal or fatal injury. This operating manual contains important details concerning the safe operation of this tool. The user must read and understand these details before any use of the tool.

This manual must be retained for future reference.

- BEFORE OPERATING PUMP, open petcock valve (breather) located on TOP of pump assembly by turning COUNTERCLOCKWISE.

Top view of pump

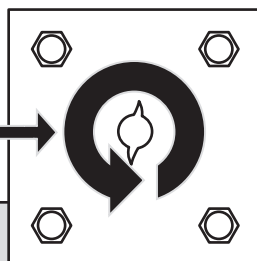

⚠ WARNING

DO NOT attempt to operate pump unless the BREATHER VALVE IS OPEN. Valve is closed prior to shipping to prevent the loss of hydraulic fluid.

- CLOSE the valve located on the FRONT of the pump assembly by turning CLOCKWISE.



⚠ CAUTION

HAND TIGHTEN VALVE ONLY. Excess pressure could damage the valve assembly.

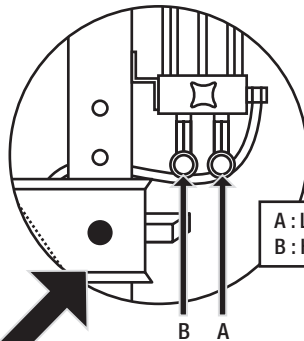
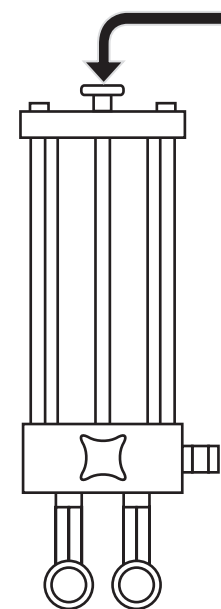

A : Low Pressure Cradle
B : High Pressure Cradle

- Insert pump handle into low pressure cradle. Use the low pressure pump until ram comes into contact with item to be pressed.

- Once ram is in contact with the item to be pressed, insert pump handle into high pressure side. Using the high pressure pump moves the ram less with each stroke and requires less effort to apply pressure.

- To relieve pressure and retract ram, turn valve located on FRONT of pump assembly ONE FULL TURN COUNTERCLOCKWISE.

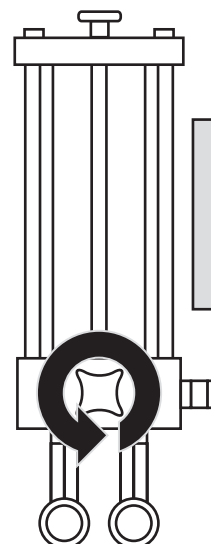





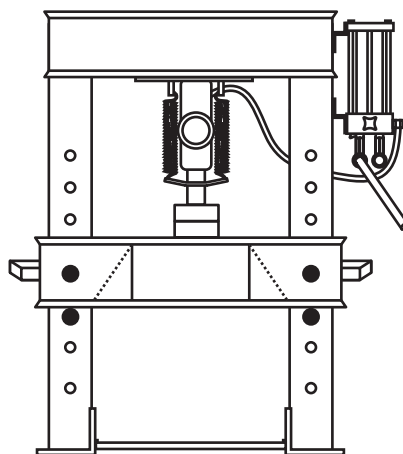
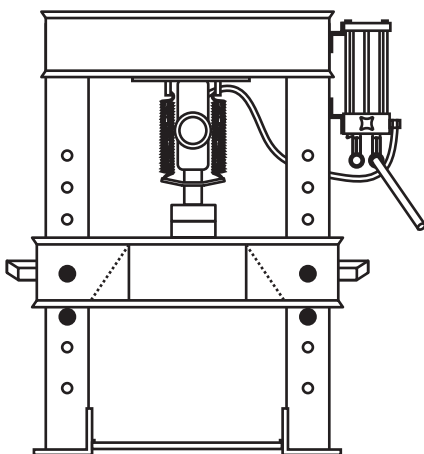

⚠ CAUTION

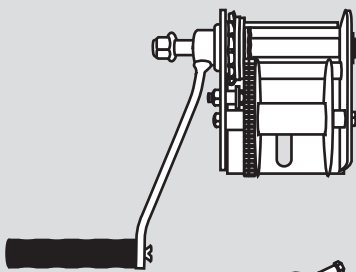
DO NOT TURN RELEASE VALVE MORE THAN ONE FULL TURN or equipment may be disabled.



WINCH KIT PARTS LIST

Winch - 1		Cable Clamp - 1	
Long Cable - 1		1/2"-13 x 1-1/2" Hex Head Bolts - 2	
Short Cable- 1		1/2" Nuts - 2	
		Washers - 2	

WINCH INSTALLATION INSTRUCTIONS

12

-  Dark Gray- Long Cable
-  Light Gray- Short Cable

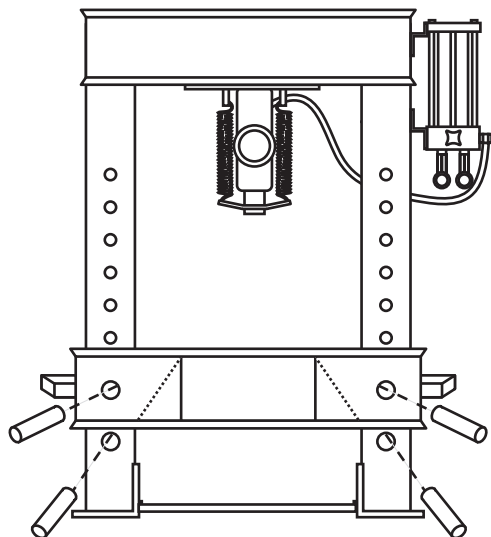

1. Move press bed into LOWEST position so it is resting on top of pins 1 and 2.

Right side of press,
under pump assembly

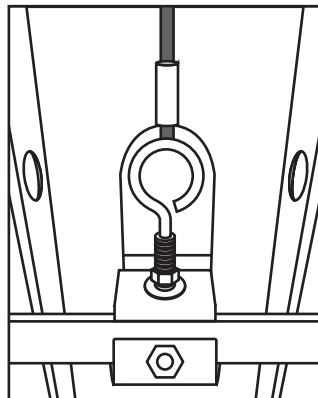

2. Install pre-attached eye bolt on LONGER cable to press bed handle located *under pump assembly*. DO NOT FULLY TIGHTEN. Center with side of press bed and make sure there is enough room to lower or raise both nuts on eye bolt for precise alignment.

⚠ WARNING

DO NOT FULLY TIGHTEN.

Right side of press

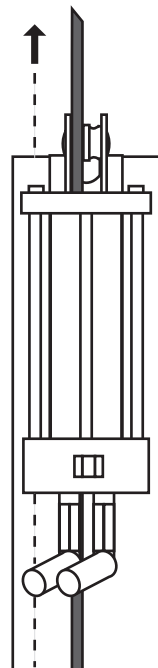

3. Thread the BARE end of the LONGER of the two steel cables up and through the pump bracket.

Note: Refer to manual from winch manufacturer for detailed instructions on winch assembly and cable threading procedure.

WINCH INSTALLATION INSTRUCTIONS

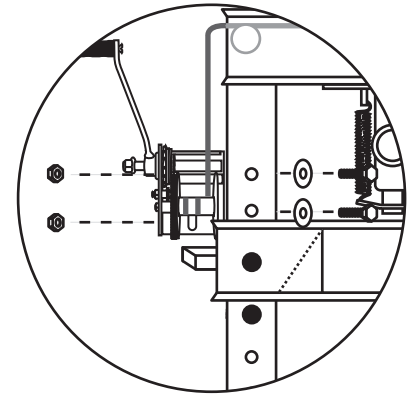
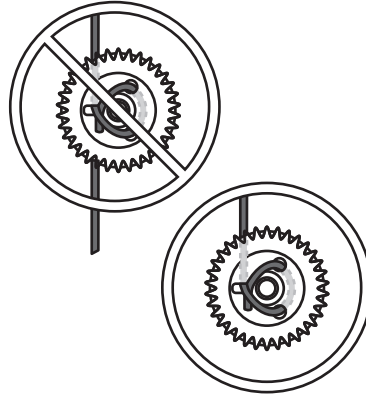
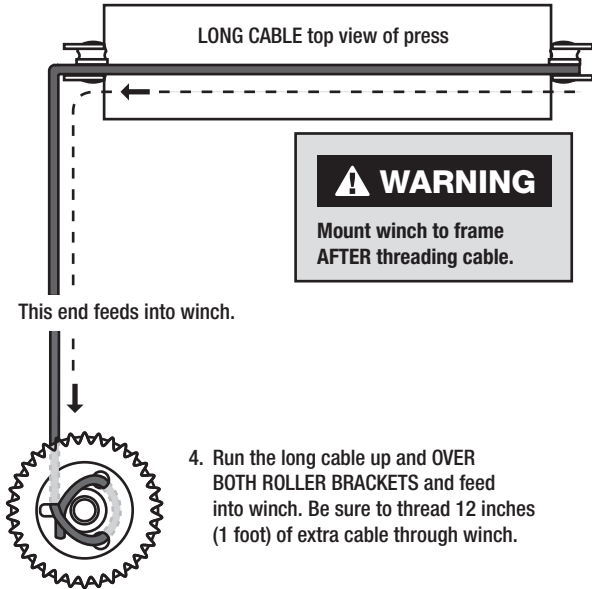

4. Run the long cable up and OVER BOTH ROLLER BRACKETS and feed into winch. Be sure to thread 12 inches (1 foot) of extra cable through winch.

5. Once winch cable has been threaded, pull excess cable back through winch as shown in diagram above. The cable should be locked tightly around itself with no excess cable left hanging. Operate winch enough to remove slack from longer cable.

6. Mount winch to frame using the provided washers, 1/2" nuts and 1/2"-13 x 1-1/2" bolts.

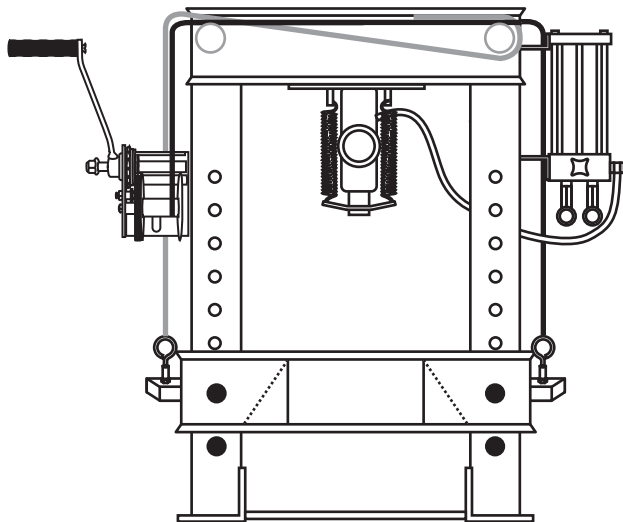

Top view of press with bed in lowest position

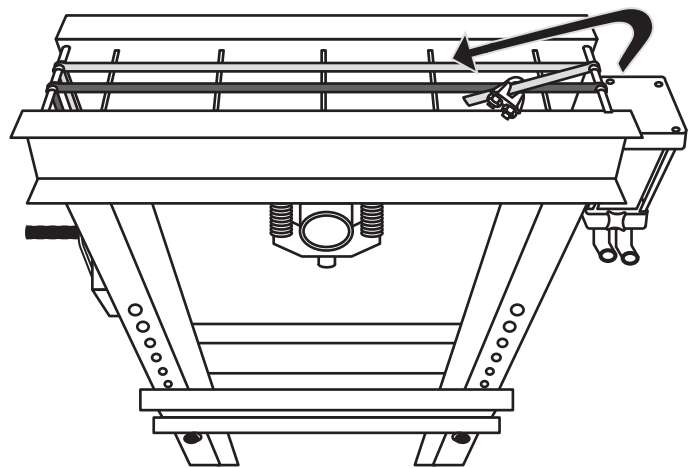

7. Feed the short cable by running it up and OVER first roller, then UNDER second roller. Loop the short cable back toward the winch and securely attach to the longer cable using the cable clamp. Remove slack from short cable before securing to long cable. Clamp should be NO LESS THAN ONE INCH (1") from roller.

Left side of press, under winch

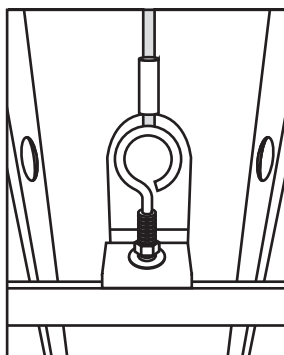

8. Install pre-attached eye bolt on SHORTER cable to press bed handle located under winch after feeding it around in step 7.

9. Turn eye hooks to adjust and level press bed. Once bed is level, firmly tighten eye hook mounting hardware. The steel cable will stretch with use. It may be necessary to repeat this leveling procedure in the future.

10. Test the winch kit by raising and lowering the press bed from its lowest to highest position. Repeat and adjust until bed is level and moves freely throughout its entire range of motion. Cut excess cable when all adjustments are complete.

We want to know if you have any problems with our products. If you are missing any parts or find any damage, call Arcan directly, and we will remedy the situation. Please do not call the store where you purchased this product.

Phone: (800) 879-7316
Email: arcanusa@bellsouth.net

REPLACEMENT PARTS LIST

CP500 - 50 TON MANUAL SHOP PRESS WITH WINCH

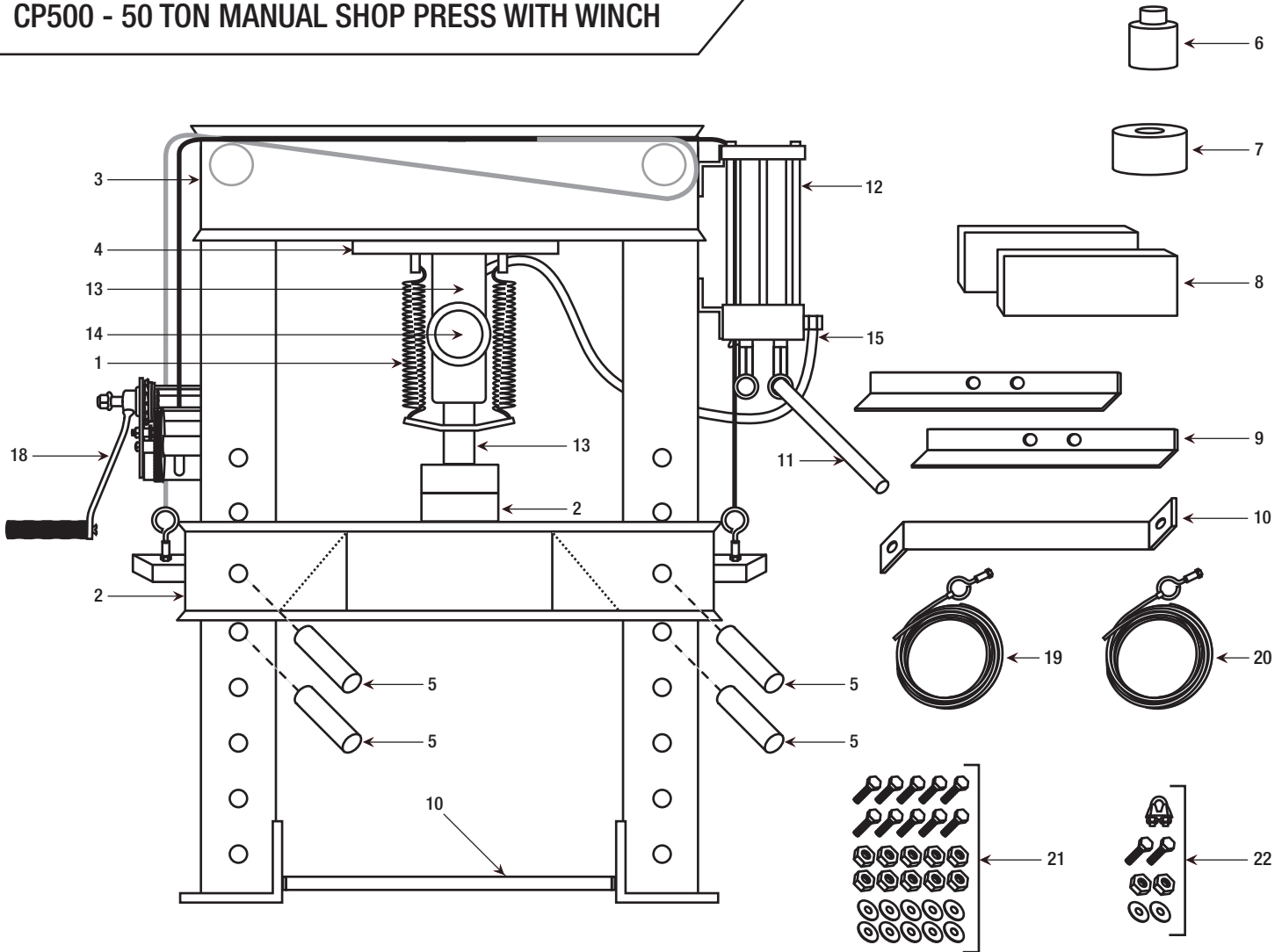

ITEM NO.	ARCAN PART NO.	DESCRIPTION	QTY.	ITEM NO.	ARCAN PART NO.	DESCRIPTION	QTY.
1	RS345009	Press Spring	2	15	RSCBP1204	Hose & Fitting	1
2	† CP50002	Press Bed	1	16	RSCBP1201	Pump & Ram Assembly**	1
3	† CP50003	Press Frame	1	17	RSCBP1217	Seal Kit for Pump and Ram (not shown)	1
4	† CP50004	Ram Frame	1	18	RS40MPW	Winch	1
5	RSCBP1225	Press Pin	4	19	RS40MPSC	Short Cable (includes eye bolt)	1
6	RS310012	Pushing Adapter	1	20	RS40MPLC	Long Cable	1
7	RSBS1	Bearing Shield	1	21	RS40MPPHK	Press Hardware Kit	1 set
8	RSCBP1205	Press Plate	2			1/2"-13 x 1-1/2" Hex Head Bolt	10
9	RSCBP1211	Press Feet	2			1/2" Nut	10
10	RSCBP1212	Z Bar	1			Washer	10
11	RSCBP1209	Pump Handle	1	22	RSWHK	Winch Hardware Kit	1 set
12	RSCBP1201B	Pump (includes handle)	1			Cable Clamp	1
13	RSCBP1202	Ram	1			1/2"-13 x 1-1/2" Hex Head Bolt	2
14	RSCBP1206	Gauge	1			1/2" Nut	2
						Washer	2

Items identified with a cross (†) are not available separately.

**Pump and Ram Assembly includes pump, ram, gauge, and hose & fitting (item numbers: 12, 13, 14 & 15)

PUMP AND RAM EXPLODED PARTS DIAGRAM

See Replacement Parts List for parts available separately.

Parts with (*) are only available in Seal Kit, part number RSCBP1217.

Individual parts pictured are components of the Seal Kit, RSCBP1217.

RAM

ITEM NO.	DESCRIPTION	QTY.
1	Base Weldment	1
2	Plug	1
3	* Polypak Seal (Parker)	2
4	1/2-13 x 2 Hex HD C-S GR 2 Zinc	1
5	Piston	1
6	* O-Ring (Parker)	1
7	Rod	1
8	Retaining Ring Int. 3.5 NOM	1
9	Piston Guide	1
10	Retractor Plate	1
11	Spring	2
12	Fitting Gauge 1.75	1
13	Gauge	1
14	90° Elbow 1/4 NPTF to -6 JIC	1
15	Hose Hydraulic 41 1/2 LG 7/16-20 JICF	1

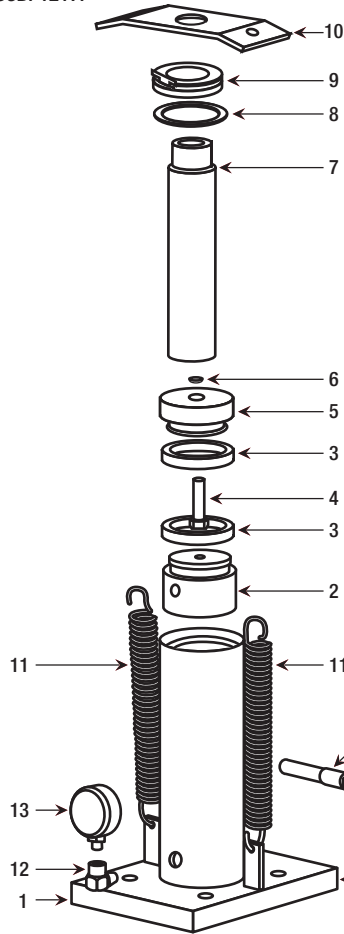

PUMP

ITEM NO.	DESCRIPTION	QTY.
1	Tank	1
2	Tie Rod	4
3	1" Piston Body	1
4	1/2" Piston Body	1
5	1" Piston	1
6	1/2" Piston	1
7	1/4" MNPT Pressure Plug	1
8	Pump Body	1
9	Pump Lid	1
10	Pump Bracket	2
11	Valve Assembly	1
12	Pivot Pin	2
13	* 5/16 Steel Ball	5
14	Brass Drain Cock	1
15	Cradle Assembly	2
16	Hydraulic Hose 41-1/2" L 7/16-20 JICF	1
17	7/16-14 Fin Hex Nut Zinc	4
19	* O-Ring	1
20	* O-Ring	1
21	* 3-1/2" Seal	2
22	* 3-5/16" Seal	1
23	* 3-3/16" Seal	1
24	SHCS 7/16 14 x 1/2"	4
25	SHCS 7/16 14 x 3/4"	4
26	* Light Spring	2
27	* Heavy Spring	2
28	7/16" Split Lock Washer	6
29	Pump Filter	1
30	Pump Fitting 1/4" MNPT 7/16" JICF	1
31	7/8" Grip	1
32	Handle for Pump	1
33	* O-Ring	1

